

## FLEUR DE NUIT

During the day, a city's infrastructure consists of many in-between places that serve the public; a parking lot is a location to leave one's car as they go to work, an alleyway is a quick route to travel through, and a sidewalk supports pedestrian traffic as they cross vehicle roadways. In the night these spaces become vacant, considered unusable space until the sun rises in the morning. This project is an exploration on how one could begin to transform these spaces to retain functionality in all 24 hours of the day. The intention is to provide a recreational program that reflects the sense of liberty one can experience in the free hours of the night, while also feeling safe. Consider the evening primrose, a flower which has evolved to only open at night; during the day its closed form acts on its need for survival, but in darkness it is transformed into an entirely different entity. We imagine our space to operate in the same fashion. The blooming of in-between spaces after dark informs new spaces of activity for its users.

The chosen site is a parking lot and alley located in the centre of downtown Sudbury, Ontario, a location in great need of revitalization. Its proximity to areas occupied throughout both night and day provide opportunity for congregation in a centralized space. A series of adjustable umbrella shaped lanterns suspend between the two adjacent roofs of the parking lot, providing light and shelter to those inhabiting the space. These elements can fold/unfold according to the activity or the time of day as needed. The space below the lights is proposed to be a flexible gathering space which accommodates varying activities: a place to sit and socialize, a venue for films or art installations, even a location for night sports. The back alleyway is programmed as a more quiet place of gathering, featuring chairs and tables that fold down from a wall system based on the programmatic needs. Wall lights illuminate the space as the night fills the sky. Overall, the space works to create a new atmosphere that bridges the socialized difference between day and night, brought together through the interconnection of flowering and light.

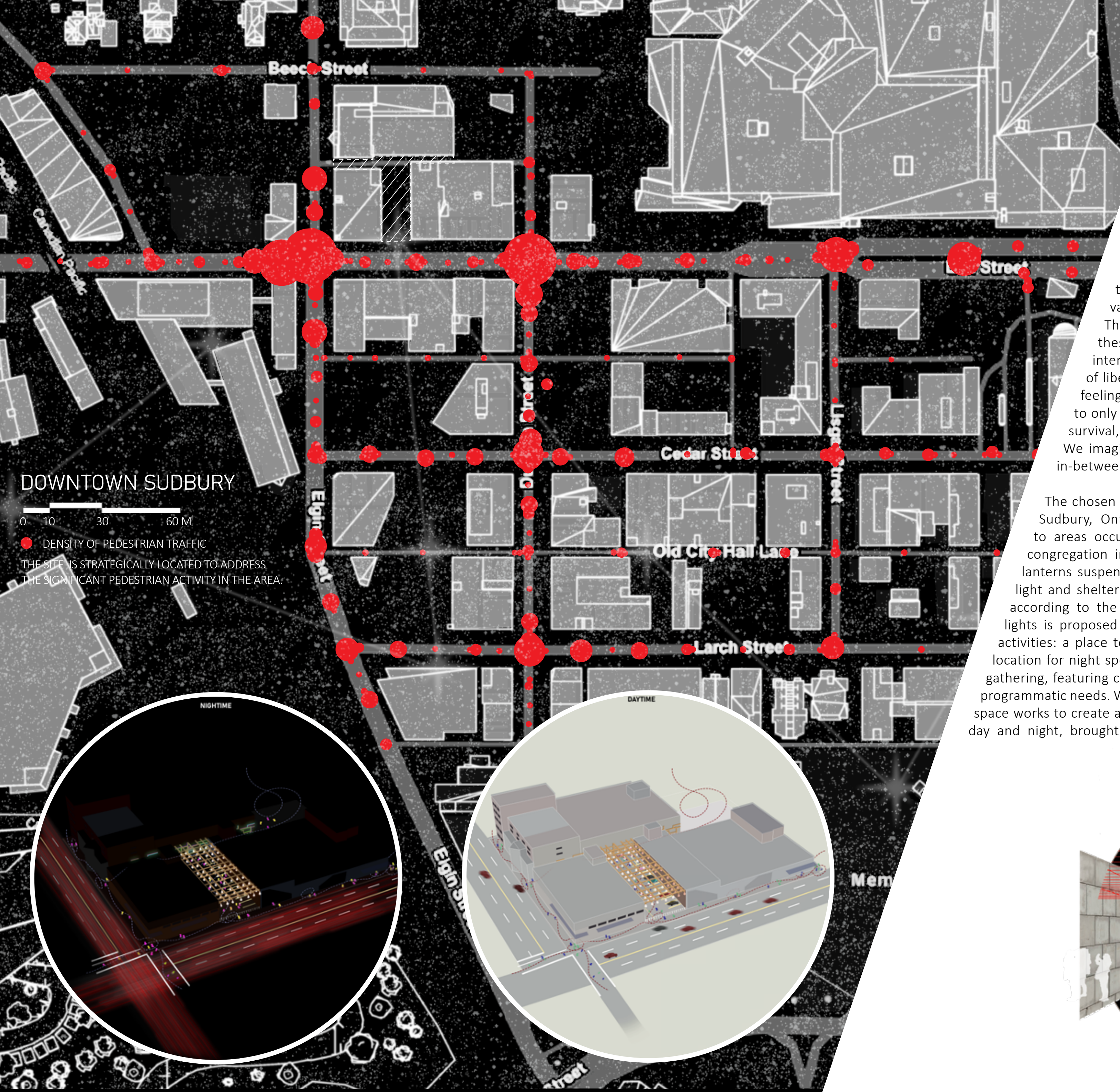
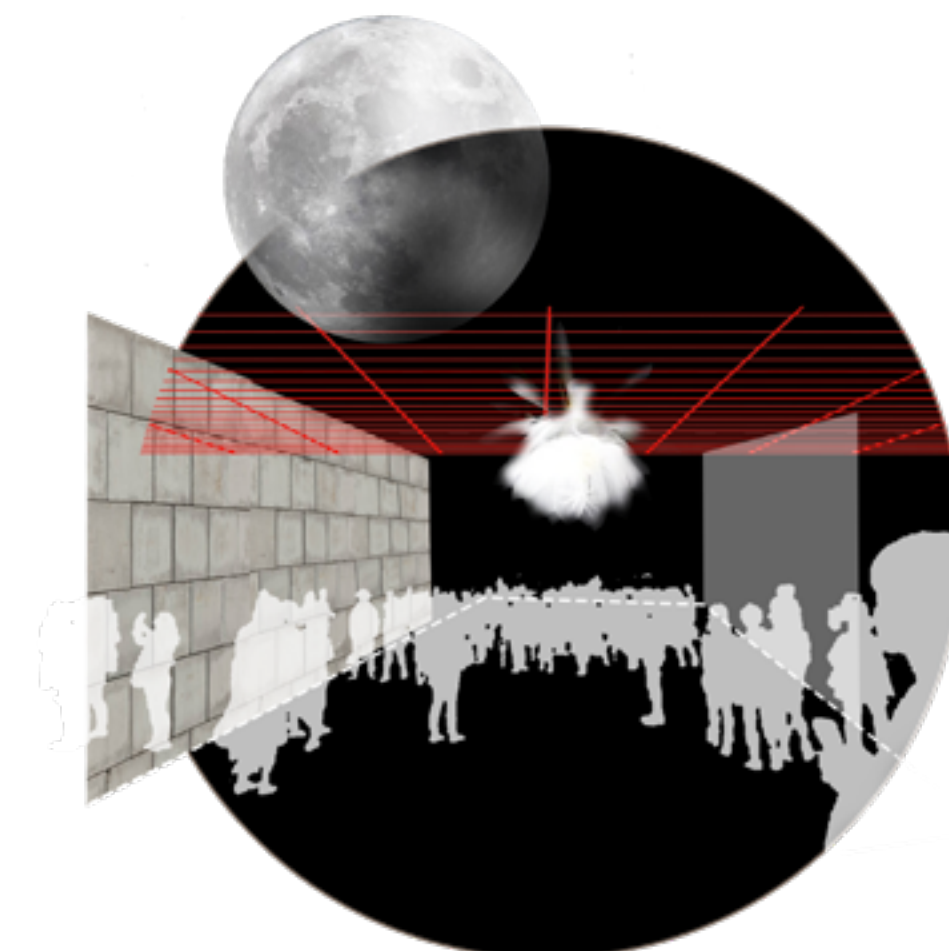

### DOWNTOWN SUDBURY



● DENSITY OF PEDESTRIAN TRAFFIC  
 THE SITE IS STRATEGICALLY LOCATED TO ADDRESS THE SIGNIFICANT PEDESTRIAN ACTIVITY IN THE AREA.

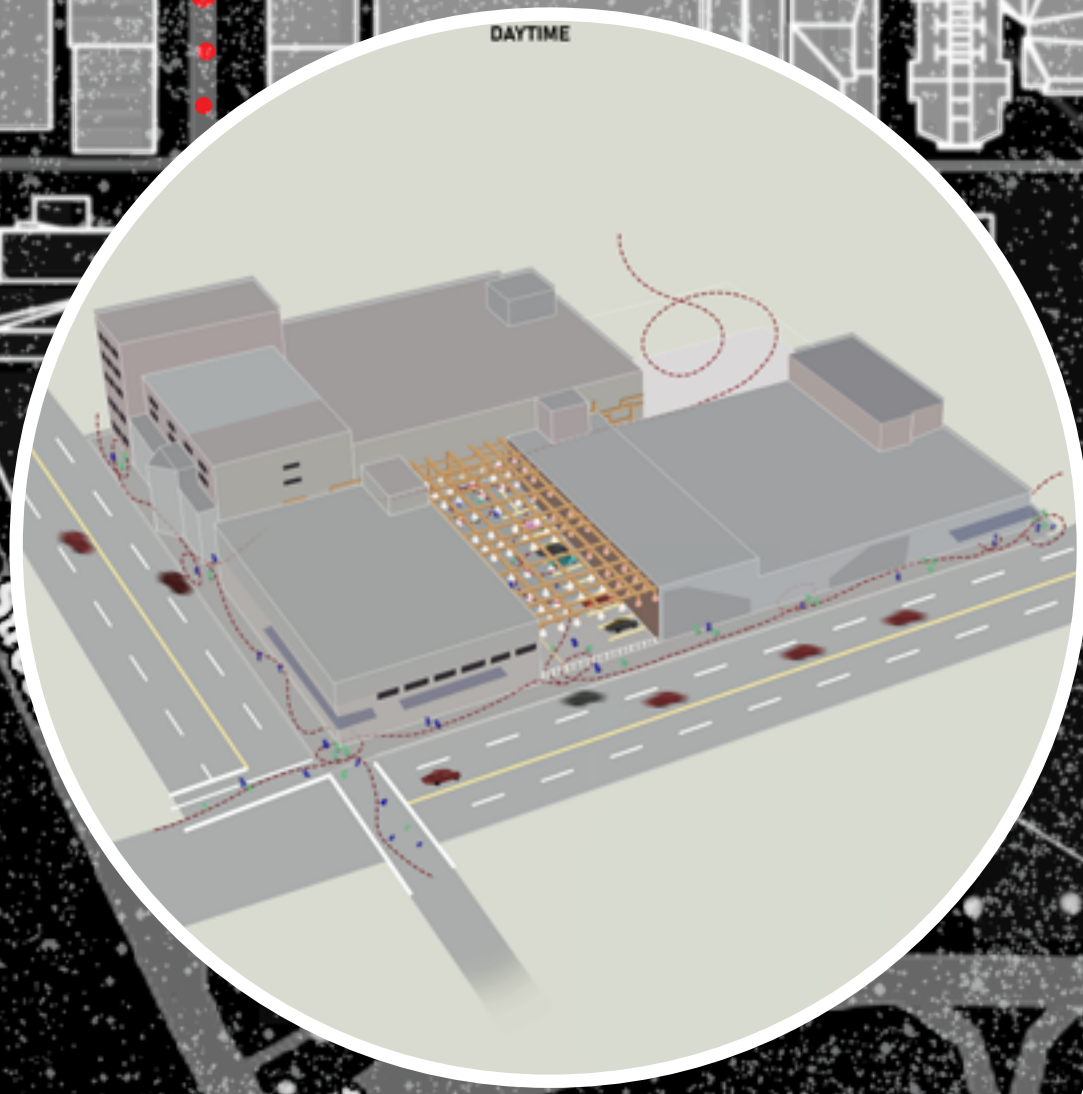
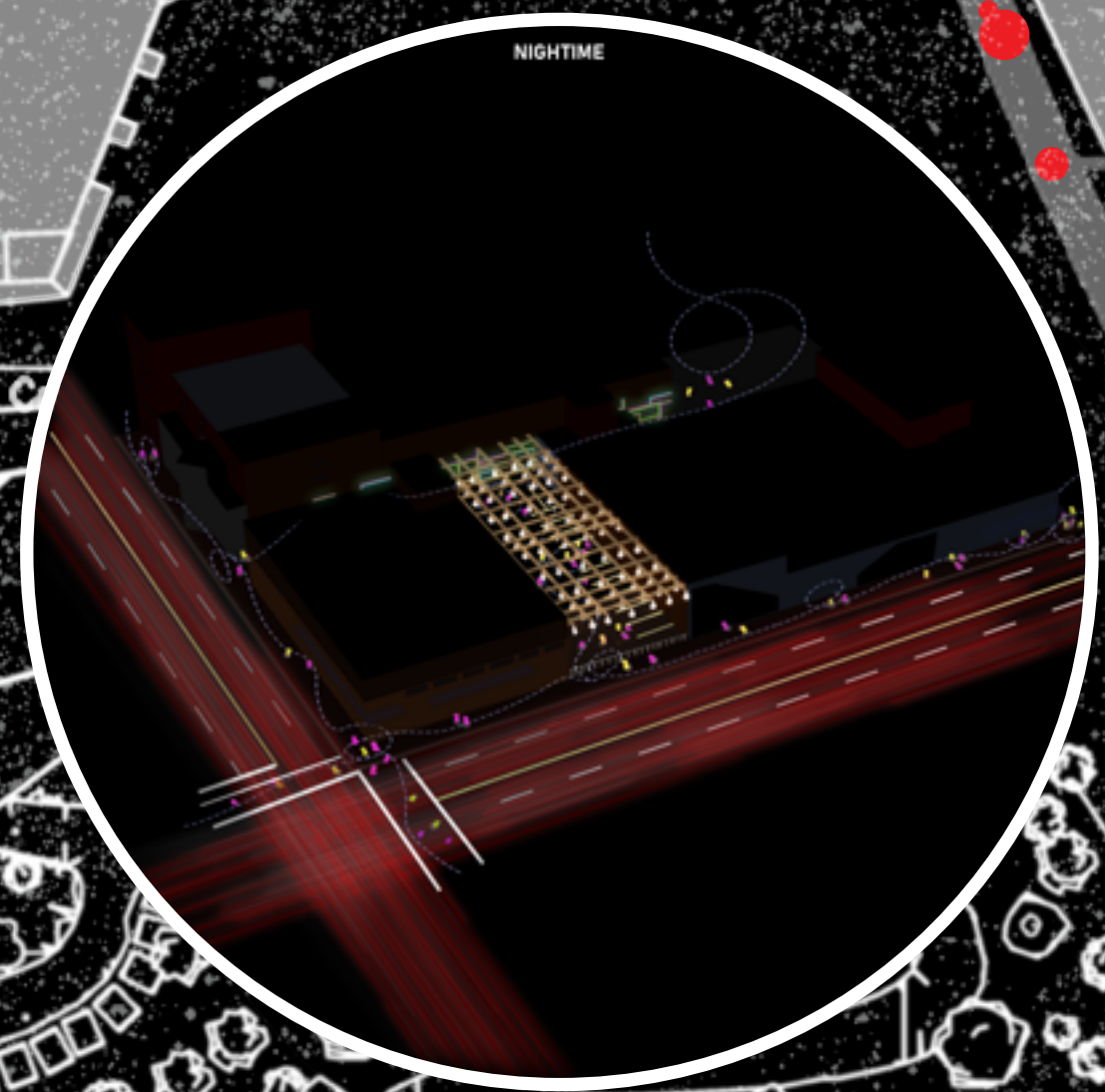





FLOWER LANTERN - CLOSED

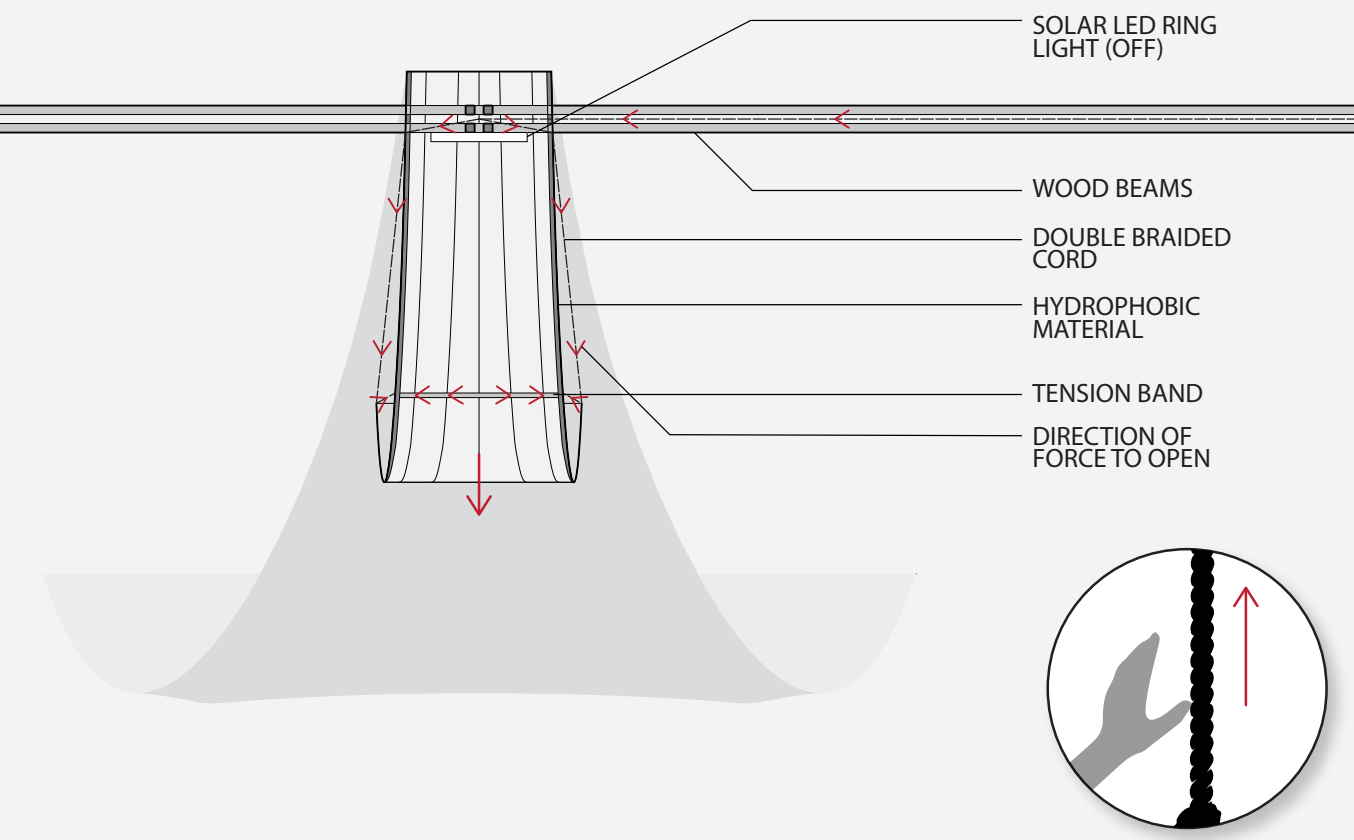

FLOWER LANTERN - OPEN

